



Shielded lamps



- The Amsterdam table lamp has a modern and endless design and integrates beautifully into any room. It is designed with clear, modern lines in brushed steel and aluminium parts. It is easy to switch on or off using a switch on the base of the lamp. It creates a beautiful look and adds atmosphere to your rooms.

This table lamp is very suitable and can be used wherever you want. A pinpoint light for working or a cosy light for ambient or background lighting, e. g. as a lamp on a sideboard or as indirect lighting when watching TV.

Special feature: The table lamp is very well shielded, making it a very low-radiation lamp, i. e. very little electrosmog, as it is fully shielded from the EU-plug to the lamp head.

- shielded table lamp made of brushed steel and brushed aluminium elements
- Tube connections, rotatable in all directions
- elegant table lamp for office and living rooms
- completely shielded from light source to mains plug incl. shielding basket and Biologa Danell LED G9



Order-no.: 400058
Short-desc.: AMSTERDAM TABLE

Shielded lamps

Table lamp AMSTERDAM

Technical data

colour:	silver, brushed steel, Shade aluminium brushed
cable length:	ca. 280 cm black
mains connection shielded:	right-angle earthing contact plug DIN 49441
switch:	1-pole, shielded ON / OFF switch in socket
operating voltage:	230 VAC / 50 Hz
dimensions:	show drawing
light source:	E14, LED-G9-5,5 W 485 lm - max. 10 Watt
protection class:	1 (with grounding wire)
shielding alternating electric field:	shielded mains cable (aluminium tape, two-wire, shielding basket)
shielding basket:	spiral stainless steel with mounting ring E14
shielding alternating magnetic field:	number of beats 10 (individual wires twisted together ten times per metre)
test according to:	TCO'99 (MPR II, DIN EN 50279) limits undercut by a factor of 20 and more for all measurement methods, undercut by a factor of 20 and more, individually by 100

Scope of delivery

lamp with one G9-LED-5,5 and shielding basket
operating instructions



Shielding effect in comparison (applies to all Biologa Danell lamps):

An unshielded luminaire (protection class 2) with an unshielded connecting cable produces an alternating electric field of 100.0 to 160.0 V/m (building biology recommended guide value 10.0 V/m).

The shielded luminaire (protection class 1) with appropriate construction produces only an alternating electric field of a minimum of 0.4 to 0.6 V/m.

The shielding is checked according to the specifications, frequency bands and measuring distances of the recognised screen standards (for low-radiation screens / monitors): TCO'99, Band I (MPR II) and DIN EN 50279 (measuring distance 30 cm).



Shielded lamps

Table lamp AMSTERDAM

Shielded lamps

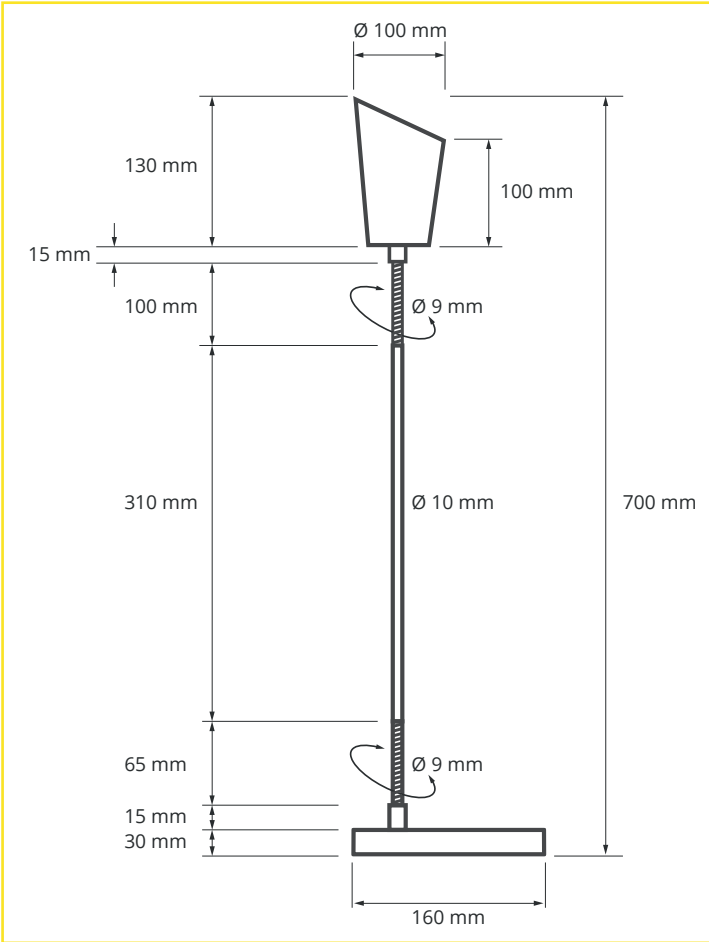

Order-no.: 400058
Short-desc.: AMSTERDAM TABLE

Shielded lamps and connection cables

A step towards healthier living and working

■ **Why shielding against electric and magnetic fields?**

Electric and magnetic fields occur everywhere. Their origin is both natural and artificial. Artificially generated fields in particular are becoming increasingly important.

The use of electrical and electronic devices in the living and working environment is constantly increasing.

The influence of artificially generated fields on the human organism has not yet been conclusively researched, but there is increasing note that people react sensitively to exposure to electric and/or magnetic fields.

Electric fields are basically caused by every electric line, even if a connected device is not switched on. This field can be almost completely eliminated by using shielded components, without having to sacrifice comfort.

Magnetic fields only occur when a device / lamp is also switched on and thus a current flows. Magnetic fields can also be significantly reduced by the appropriate design of a lamp.

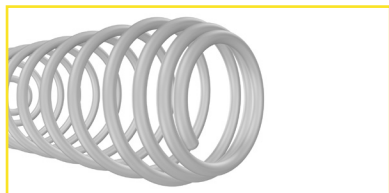
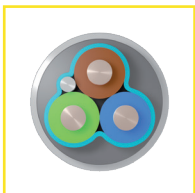

■ **Practical construction of shielded lamps**

Our shielded lamps basically consist of a three-pole connecting cable, a metal lamp housing of protection class I and a shielding basket for the light source.

While conventional mains cables are usually designed with two poles and a Euro plug, our cables have three poles (with protective conductor, increased safety) and are equipped with a metallic sheathing of the core as a shield.

Our lamps have a metallic housing (or inner housing in the case of lamps made of wood) which, unlike other materials such as plastic or wood, also shields against the alternating electric field.

Lamp socket and light source (according to building biology recommendations) were integrated into the shielded system by means of a shielding basket, as considerable alternating electric fields can be measured here as well without shielding.

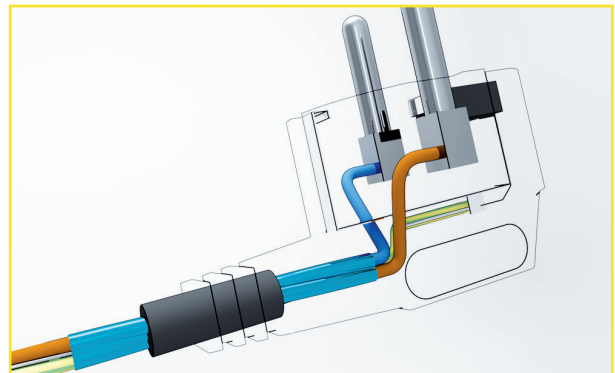

Shielding effect in comparison

An unshielded lamp (protection class 2) with an unshielded connecting cable produces an alternating electric field of 100.0 to 160.0 V/m (building biology recommended guide value 10.0 V/m). The shielded lamp (protection class 1) with a corresponding construction only produces an alternating electric field of a minimum of 0.4 to 0.6 V/m.

The screening is checked according to the specifications, frequency bands and measuring distances of the recognised screen standards (for low-radiation screens / monitors): TCO'99, Band I (MPR II) and DIN EN 50279 (measuring distance 30 cm)..

What else can be done?

- Only use shielded connection cables and socket strips for your other devices!
- Never leave appliances switched on or in stand-by mode for longer than necessary; always unplug the appropriate mains plug or switch off two-pole.
- Avoid electrical appliances in your bedrooms or living rooms or place them as far away from you as possible.

Generally useful notes on the subject of „electrosmog“ can be found on the Internet at:

- www.verband-baubiologie.de
- www.baubiologie.net
- www.baubiologie.de

All product information on shielded cables, connecting cables, socket strips and lamp systems can be found under: www.biologadanell.com.



Table lamp AMSTERDAM - Instruction manual

TABLE LAMP AMSTERDAM - 400058



■ Initial operation

1. Remove packaging material
2. Insert G9 light source
3. Connect the cable to the socket
4. Switching on and off with ON / OFF switch

■ Changing the light source

Attention, important note:

For all work on the lamp, always disconnect the mains plug first!

Press the screen basket down from above

1. Remove the defective lamp and insert the new lamp. Let the lampshade basket slowly escape upwards under its own power.

■ Insert G9 light source / change light source G9

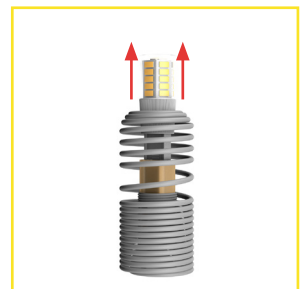
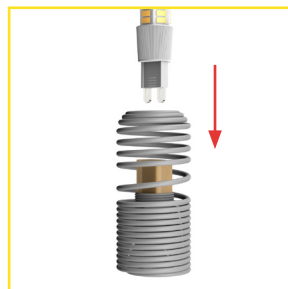
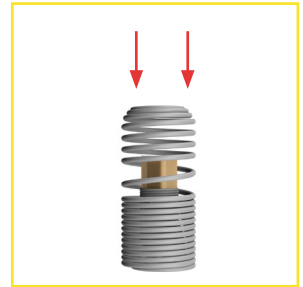
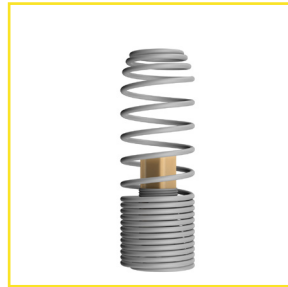
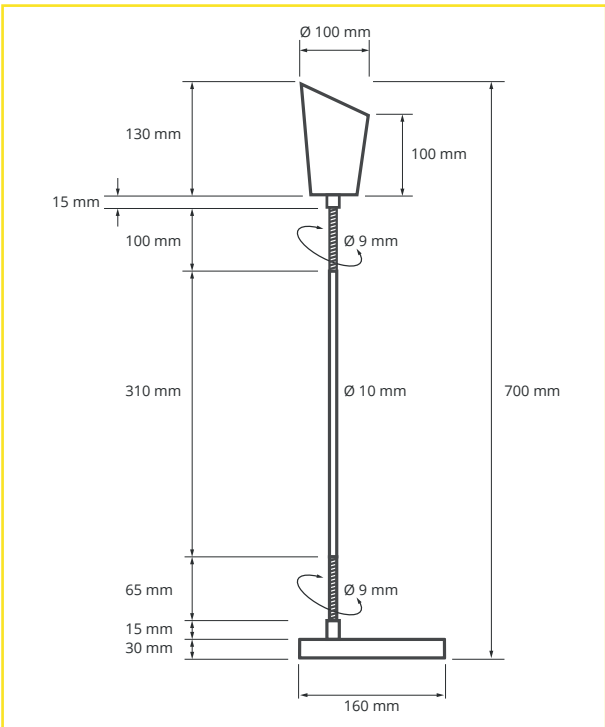

Safety instructions

All electrical work (work on electrical equipment and installations) must be carried out and inspected by a qualified electrician or under their direction and supervision!

Use your lamp only in normally tempered, dry indoor rooms. No outdoor use!

